

For some time the German Federal Office for Goods Traffic (BAG) have been checking the correct locked position of the TW coupling lever on chemical and mineral oil road tankers at road side testings.

Fines were issued when damaged parts or loose levers were found on the female coupler.

TW female coupling to EN 14420-6 features several safeguards to avoid accidental disconnection of the female coupler in combination with male adapters or dust plugs, see picture.

The lever should be locked in a vertical position to prevent unintended decoupling of the lever. If a 'close fit' of the lever is not possible due to limited space female couplers are also available with bent levers, see Elaflex Information 7.06.

If the spring of the handle is broken the function of the locking lever and the coupling lock is compromised and may rotate loose or disconnect completely during operation due to pulsation or vibrations.

To address this issue Elaflex only supplies female couplers with stainless steel springs.

We recommend that all users check the functioning of the couplings and exchange damaged or worn parts on a regular basis. This applies in particular to female couplings which are used to connect vehicle pipes together with dust plugs.

Other components can be supplied in order to make certain one way or the other – see page overleaf.

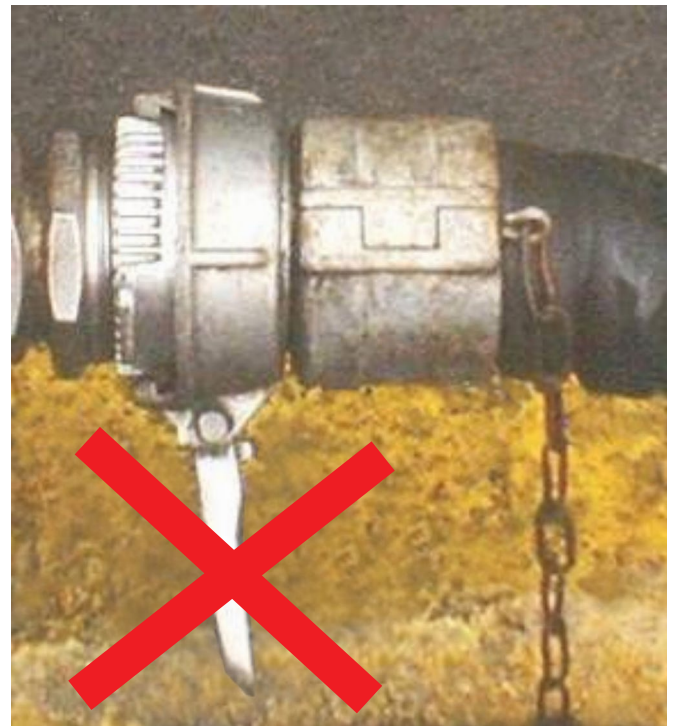
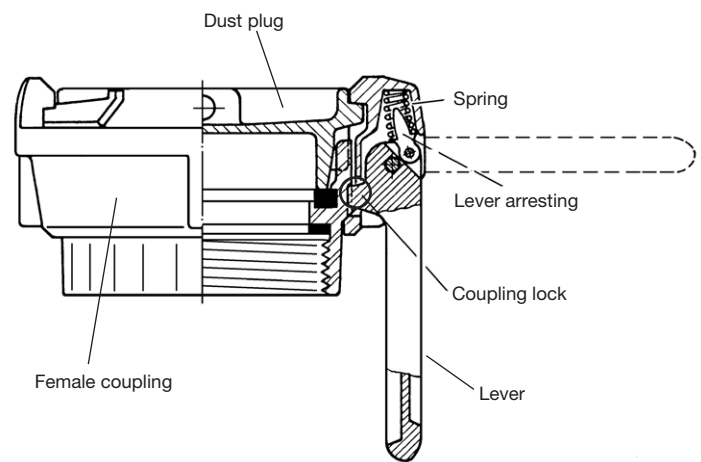

Female Couplers with Active Safeguard Lever:

TW female couplings of stainless steel have been supplied as special type **MK-A ... SS** with active safeguard lever for many years now, see Elaflex Information 6.06.

The lever is automatically locked when the lever lays flat with the coupling assembly. An accidental lifting of the lever lifting is not possible.

Hint: deliverable in sizes DN 50, 80 and 100.



TW female coupling with active safeguard lever

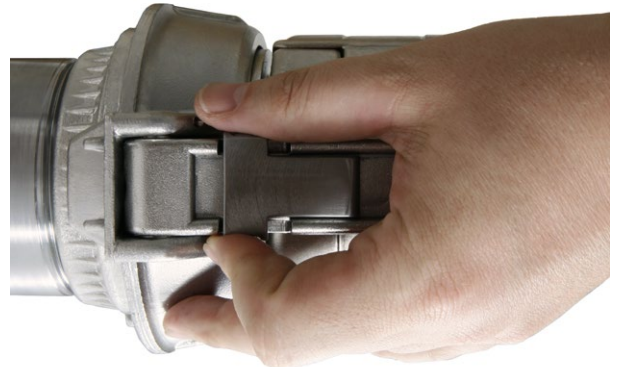

Dust Plugs With Pressure Relief Valve:

The special type **VB .. ADR** has been available for many years now, see Elaflex Information 9.11.

The reason for this development is that the ADR requirement states (current version 2015) that dust plugs have to enable a safe pressure release in the discharge pipe before the closing device can be completely removed.

This special type with a locking pin will also prevent an uncontrolled lifting of the dust plug in case of a damaged locked lever of the female coupler.

Hint: available in DN 80 stainless steel version and DN 100 aluminium version.



Dust plug with lock pin / pressure relief valve



VB 100 ADR in Aluminium